

# NPTF Female Port

Stainless Steel

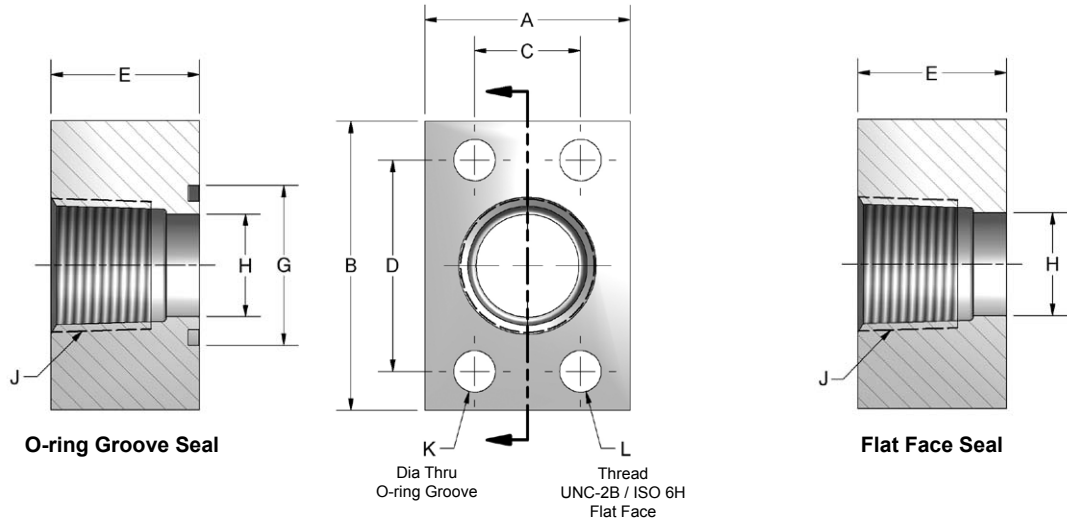
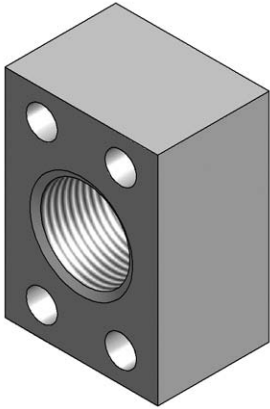

## Ordering Information

FG	Flange Size	Material	Product Type	Seal	Rating Code	Port Size	Port Type	Mounting																																																																																
	<table border="1"> <thead> <tr> <th colspan="2">Flange Size</th> </tr> </thead> <tbody> <tr> <td colspan="2">Rating code 1 or 2</td> </tr> <tr> <td>08</td> <td>0.50"</td> </tr> <tr> <td>12</td> <td>0.75"</td> </tr> <tr> <td>16</td> <td>1.00"</td> </tr> <tr> <td>20</td> <td>1.25"</td> </tr> <tr> <td>24</td> <td>1.50"</td> </tr> <tr> <td>32</td> <td>2.00"</td> </tr> <tr> <td colspan="2">Rating code 1 only</td> </tr> <tr> <td>40</td> <td>2.50"</td> </tr> <tr> <td>48</td> <td>3.00"</td> </tr> </tbody> </table>	Flange Size		Rating code 1 or 2		08	0.50"	12	0.75"	16	1.00"	20	1.25"	24	1.50"	32	2.00"	Rating code 1 only		40	2.50"	48	3.00"	<table border="1"> <thead> <tr> <th colspan="2">Material</th> </tr> </thead> <tbody> <tr> <td>S</td> <td>Stainless Steel</td> </tr> </tbody> </table>	Material		S	Stainless Steel	<table border="1"> <thead> <tr> <th colspan="2">Product Type</th> </tr> </thead> <tbody> <tr> <td>F</td> <td>Female Port</td> </tr> </tbody> </table>	Product Type		F	Female Port	<table border="1"> <thead> <tr> <th colspan="2">Seal</th> </tr> </thead> <tbody> <tr> <td>G</td> <td>O-ring Groove</td> </tr> <tr> <td>F</td> <td>Flat Face</td> </tr> </tbody> </table>	Seal		G	O-ring Groove	F	Flat Face	<table border="1"> <thead> <tr> <th colspan="2">Rating Code</th> </tr> </thead> <tbody> <tr> <td>1</td> <td>Code 61 • SAE J518 3.5 - 35 MPa • ISO 6162-1</td> </tr> <tr> <td>2</td> <td>Code 62 • SAE J518 40 MPa • ISO 6162-2</td> </tr> </tbody> </table>	Rating Code		1	Code 61 • SAE J518 3.5 - 35 MPa • ISO 6162-1	2	Code 62 • SAE J518 40 MPa • ISO 6162-2	<table border="1"> <thead> <tr> <th colspan="2">Port Size</th> </tr> </thead> <tbody> <tr> <td colspan="2">Not all port sizes are available for each flange size. See chart next page.</td> </tr> <tr> <td>08</td> <td>0.50"</td> </tr> <tr> <td>12</td> <td>0.75"</td> </tr> <tr> <td>16</td> <td>1.00"</td> </tr> <tr> <td>20</td> <td>1.25"</td> </tr> <tr> <td>24</td> <td>1.50"</td> </tr> <tr> <td>32</td> <td>2.00"</td> </tr> <tr> <td>40</td> <td>2.50"</td> </tr> <tr> <td>48</td> <td>3.00"</td> </tr> </tbody> </table>	Port Size		Not all port sizes are available for each flange size. See chart next page.		08	0.50"	12	0.75"	16	1.00"	20	1.25"	24	1.50"	32	2.00"	40	2.50"	48	3.00"	<table border="1"> <thead> <tr> <th colspan="2">Port Type</th> </tr> </thead> <tbody> <tr> <td>P</td> <td>NPTF ANSI B1.20.3</td> </tr> </tbody> </table>	Port Type		P	NPTF ANSI B1.20.3	<table border="1"> <thead> <tr> <th colspan="2">Mounting</th> </tr> </thead> <tbody> <tr> <td colspan="2">Seal code G only</td> </tr> <tr> <td>U</td> <td>UNC mounting kit</td> </tr> <tr> <td>M</td> <td>Metric mounting kit</td> </tr> <tr> <td colspan="2">Seal code G or F</td> </tr> <tr> <td>X</td> <td>No kit included UNC mounting holes</td> </tr> <tr> <td>Y</td> <td>No kit included Metric mounting holes</td> </tr> </tbody> </table>	Mounting		Seal code G only		U	UNC mounting kit	M	Metric mounting kit	Seal code G or F		X	No kit included UNC mounting holes	Y	No kit included Metric mounting holes
Flange Size																																																																																								
Rating code 1 or 2																																																																																								
08	0.50"																																																																																							
12	0.75"																																																																																							
16	1.00"																																																																																							
20	1.25"																																																																																							
24	1.50"																																																																																							
32	2.00"																																																																																							
Rating code 1 only																																																																																								
40	2.50"																																																																																							
48	3.00"																																																																																							
Material																																																																																								
S	Stainless Steel																																																																																							
Product Type																																																																																								
F	Female Port																																																																																							
Seal																																																																																								
G	O-ring Groove																																																																																							
F	Flat Face																																																																																							
Rating Code																																																																																								
1	Code 61 • SAE J518 3.5 - 35 MPa • ISO 6162-1																																																																																							
2	Code 62 • SAE J518 40 MPa • ISO 6162-2																																																																																							
Port Size																																																																																								
Not all port sizes are available for each flange size. See chart next page.																																																																																								
08	0.50"																																																																																							
12	0.75"																																																																																							
16	1.00"																																																																																							
20	1.25"																																																																																							
24	1.50"																																																																																							
32	2.00"																																																																																							
40	2.50"																																																																																							
48	3.00"																																																																																							
Port Type																																																																																								
P	NPTF ANSI B1.20.3																																																																																							
Mounting																																																																																								
Seal code G only																																																																																								
U	UNC mounting kit																																																																																							
M	Metric mounting kit																																																																																							
Seal code G or F																																																																																								
X	No kit included UNC mounting holes																																																																																							
Y	No kit included Metric mounting holes																																																																																							



# NPTF Female Port

Stainless Steel

CODE 61 NPTF FEMALE PORT																	
FLANGE SIZE	PORT SIZE	A	B	C	D	E	G	H	J NPTF	K DIA THRU		L THREAD		MOUNTING HARDWARE SHCS			
										Mounting U or X	Mounting M or Y	UNC-2B U or X	ISO 6H M or Y	O-RING	Mounting U	Mounting M	
0.50	0.50	1.50	2.12	.688	1.500	1.20	1.000	.502	.50	.344	8.5mm	0.313-18	M8-1.25	210	0.313-18X1.75	M8-1.25x45	
0.75	0.75	1.75	2.62	.875	1.875	1.20	1.250	.752	.75	.406	10.5mm	0.375-16	M10-1.5	214	0.375-16X2.00	M10-1.5x50	
1.00	1.00	2.00	2.82	1.031	2.062	1.45	1.560	1.002	1.00	.406	10.5mm	0.375-16	M10-1.5	219	0.375-16X2.25	M10-1.5x55	
1.25	1.25	2.50	3.19	1.188	2.312	1.45	1.750	1.252	1.25	.469	10.5mm	0.438-14	M10-1.5	222	0.438-14X2.25	M10-1.5x55	
1.50	1.50	2.75	3.75	1.406	2.750	1.70	2.115	1.502	1.50	.531	12.5mm	0.500-13	M12-1.75	225	0.500-13X2.50	M12-1.75x65	
2.00	2.00	3.25	4.00	1.688	3.062	1.70	2.490	2.002	2.00	.531	12.5mm	0.500-13	M12-1.75	228	0.500-13X2.50	M12-1.75x65	
2.50	2.50	4.00	4.50	2.000	3.500	1.95	2.995	2.502	2.50	.531	12.5mm	0.500-13	M12-1.75	232	0.500-13X2.75	M12-1.75x70	
3.00	3.00	4.50	5.31	2.438	4.188	2.20	3.615	3.002	3.00	.656	16.5mm	0.625-11	M16-2.0	237	0.625-11X3.00	M16-2.0x75	

CODE 62 NPTF FEMALE PORT																	
FLANGE SIZE	PORT SIZE	A	B	C	D	E	G	H	J NPTF	K DIA THRU		L THREAD		MOUNTING HARDWARE SHCS			
										Mounting U or X	Mounting M or Y	UNC-2B U or X	ISO 6H M or Y	O-RING	Mounting U	Mounting M	
0.50	0.50	1.75	2.22	.718	1.594	.95	1.000	.502	.50	.344	8.5mm	5/6-18	M8-1.25	210	0.313-18X1.50	M8-1.25x40	
0.75	0.75	2.00	2.81	.937	2.000	1.20	1.250	.752	.75	.406	10.5mm	0.375-16	M10-1.5	214	0.375-16X2.00	M10-1.5x50	
1.00	1.00	2.25	3.19	1.093	2.250	1.45	1.560	1.002	1.00	.492	12.5mm	0.438-14	M12-1.75	219	0.438-14X2.50	M12-1.75x65	
1.25	1.25	2.75	3.75	1.250	2.625	1.45	1.750	1.252	1.25	.531	12.5mm	0.500-13	M12-1.75	222	0.500-13X2.25	M12-1.75x55	
1.50	1.50	3.25	4.50	1.437	3.125	1.70	2.115	1.502	1.50	.656	16.5mm	0.625-11	M16-2.0	225	0.625-11X2.75	M16-2.0x70	
2.00	2.00	4.00	5.25	1.750	3.812	1.70	2.490	2.002	2.00	.781	21.0mm	0.750-10	M20-2.5	228	0.750-10X3.00	M20-2.5x75	

### Pressure Ratings and Fastener Torque Values

CODE 61 SAE J518-1 / ISO 6162-1						
Dash Size	Inch Size	Max Working Pressure		Fastener Torque Value		
		PSI	MPa	Grade 8 UNC (lb-ft)	Grade 10.9 Metric (N-m)	
-8	0.50"	5000	35.0	24	32	
-12	0.75"	5000	35.0	44	70	
-16	1.00"	4600	32.0	44	70	
-20	1.25"	4000	28.0	68	70	
-24	1.50"	3000	21.0	111	130	
-32	2.00"	3000	21.0	111	130	
-40	2.50"	2500	17.5	111	130	
-48	3.00"	2300	16.0	218	295	
-56	3.50"	500	3.5	218	295	
-64	4.00"	500	3.5	218	295	
-80	5.00"	500	3.5	218	295	

CODE 62 SAE J518-2 / ISO 6162-2						
Dash Size	Inch Size	Max Working Pressure		Fastener Torque Value		
		PSI	MPa	Grade 8 UNC (lb-ft)	Grade 10.9 Metric (N-m)	
-8	0.50"	6000	40.0	24	32	
-12	0.75"	6000	40.0	44	70	
-16	1.00"	6000	40.0	68	130	
-20	1.25"	6000	40.0	111	130	
-24	1.50"	6000	40.0	218	295	
-32	2.00"	6000	40.0	332	550	

Please note that all pressure ratings in this catalog refer to the flange connection. Adapting the flange to other connections, such as braze tube, welded pipe, or threaded ports / stud ends could reduce maximum working pressure.