

# Butt Weld Pipe - Code 62

Stainless Steel

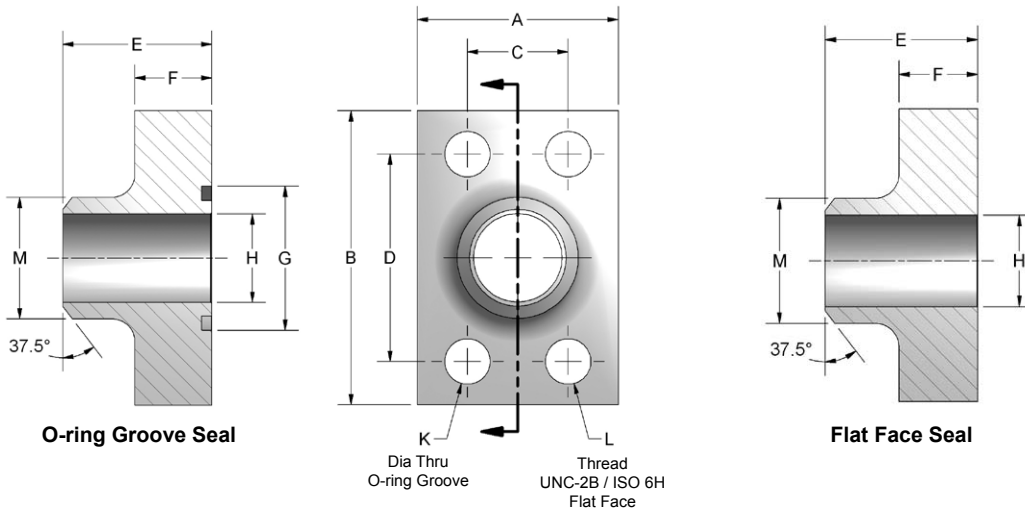
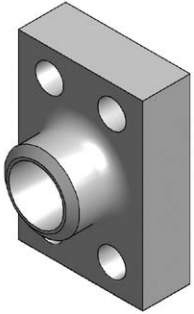

## Ordering Information

FG	Flange Size	Material	Product Type	Seal	Rating Code	Pipe Rating	Mounting																																																								
	<table border="1"> <thead> <tr> <th colspan="2">Flange Size</th> </tr> </thead> <tbody> <tr> <td>12</td> <td>0.75"</td> </tr> <tr> <td>16</td> <td>1.00"</td> </tr> <tr> <td>20</td> <td>1.25"</td> </tr> <tr> <td>24</td> <td>1.50"</td> </tr> <tr> <td>32</td> <td>2.00"</td> </tr> <tr> <td>40</td> <td>2.50"</td> </tr> <tr> <td>48</td> <td>3.00"</td> </tr> </tbody> </table>	Flange Size		12	0.75"	16	1.00"	20	1.25"	24	1.50"	32	2.00"	40	2.50"	48	3.00"	<table border="1"> <thead> <tr> <th colspan="2">Material</th> </tr> </thead> <tbody> <tr> <td>S</td> <td>Stainless Steel</td> </tr> </tbody> </table>	Material		S	Stainless Steel	<table border="1"> <thead> <tr> <th colspan="2">Product Type</th> </tr> </thead> <tbody> <tr> <td>B</td> <td>Butt Weld Pipe</td> </tr> </tbody> </table>	Product Type		B	Butt Weld Pipe	<table border="1"> <thead> <tr> <th colspan="2">Seal</th> </tr> </thead> <tbody> <tr> <td>G</td> <td>O-ring Groove</td> </tr> <tr> <td>F</td> <td>Flat Face</td> </tr> </tbody> </table>	Seal		G	O-ring Groove	F	Flat Face	<table border="1"> <thead> <tr> <th colspan="2">Rating Code</th> </tr> </thead> <tbody> <tr> <td>2</td> <td>Code 62 • SAE J518 40 MPa • ISO 6162-2</td> </tr> </tbody> </table>	Rating Code		2	Code 62 • SAE J518 40 MPa • ISO 6162-2	<table border="1"> <thead> <tr> <th colspan="2">Pipe Rating</th> </tr> </thead> <tbody> <tr> <td>080</td> <td>Schedule 80 ANSI/ASME B36.10</td> </tr> <tr> <td>160</td> <td>Schedule 160 ANSI/ASME B36.10</td> </tr> <tr> <td>XXS</td> <td>Schedule XXS ANSI/ASME B36.10</td> </tr> </tbody> </table>	Pipe Rating		080	Schedule 80 ANSI/ASME B36.10	160	Schedule 160 ANSI/ASME B36.10	XXS	Schedule XXS ANSI/ASME B36.10	<table border="1"> <thead> <tr> <th colspan="2">Mounting</th> </tr> </thead> <tbody> <tr> <td colspan="2">Seal code G only</td> </tr> <tr> <td>U</td> <td>UNC mounting kit</td> </tr> <tr> <td>M</td> <td>Metric mounting kit</td> </tr> <tr> <td colspan="2">Seal code G or F</td> </tr> <tr> <td>X</td> <td>No kit included UNC mounting holes</td> </tr> <tr> <td>Y</td> <td>No kit included Metric mounting holes</td> </tr> </tbody> </table>	Mounting		Seal code G only		U	UNC mounting kit	M	Metric mounting kit	Seal code G or F		X	No kit included UNC mounting holes	Y	No kit included Metric mounting holes
Flange Size																																																															
12	0.75"																																																														
16	1.00"																																																														
20	1.25"																																																														
24	1.50"																																																														
32	2.00"																																																														
40	2.50"																																																														
48	3.00"																																																														
Material																																																															
S	Stainless Steel																																																														
Product Type																																																															
B	Butt Weld Pipe																																																														
Seal																																																															
G	O-ring Groove																																																														
F	Flat Face																																																														
Rating Code																																																															
2	Code 62 • SAE J518 40 MPa • ISO 6162-2																																																														
Pipe Rating																																																															
080	Schedule 80 ANSI/ASME B36.10																																																														
160	Schedule 160 ANSI/ASME B36.10																																																														
XXS	Schedule XXS ANSI/ASME B36.10																																																														
Mounting																																																															
Seal code G only																																																															
U	UNC mounting kit																																																														
M	Metric mounting kit																																																														
Seal code G or F																																																															
X	No kit included UNC mounting holes																																																														
Y	No kit included Metric mounting holes																																																														

# Butt Weld Pipe - Code 62

## Stainless Steel

CODE 62 BUTT WELD - SCHEDULE 80 PIPE																	
FLANGE SIZE	PIPE SIZE	A	B	C	D	E	F	G	H	K DIA THRU		L THREAD		M	MOUNTING HARDWARE SHCS		
										Mounting U or X	Mounting M or Y	UNC-2B U or X	ISO 6H M or Y		O-RING	Mounting U	Mounting M
0.75	0.75	1.94	2.81	.937	2.000	1.42	.83	1.250	.744	.406	10.5mm	0.375-16	M10-1.5	1.050	214	0.375-16x1.50	M10-1.5x40
1.00	1.00	2.18	3.19	1.093	2.250	1.61	.83	1.560	.959	.492	12.5mm	0.438-14	M12-1.75	1.315	219	0.438-14x1.50	M12-1.75x40
1.25	1.25	2.44	3.75	1.250	2.625	1.73	.94	1.750	1.280	.531	12.5mm	0.500-13	M12-1.75	1.660	222	0.500-13x2.00	M12-1.75x50
1.50	1.50	2.81	4.44	1.437	3.125	2.17	1.10	2.115	1.502	.656	16.5mm	0.625-11	M16-2.0	1.900	225	0.625-11x2.25	M16-2.0x55
2.00	2.00	3.44	5.25	1.750	3.812	2.48	1.46	2.490	1.941	.781	21.0mm	0.750-10	M20-2.5	2.375	228	0.750-10x3.00	M20-2.5x75
2.50*	2.50	5.00	6.88	2.312	4.875	2.37	1.50	2.995	2.325	.940	25.0mm	0.875-9	M24-3.0	2.875	232	0.875-9x3.00	M24-3.0x75
3.00*	3.00	6.00	8.50	2.812	6.000	2.96	2.00	3.615	2.902	1.190	31.0mm	1.125-7	M30-3.5	3.500	237	1.125-7x4.00	M30-3.5x100

\*2.50" and 3.00" flanges have 3000 PSI Max working pressure.

CODE 62 BUTT WELD - SCHEDULE 160 PIPE																	
FLANGE SIZE	PIPE SIZE	A	B	C	D	E	F	G	H	K DIA THRU		L THREAD		M	MOUNTING HARDWARE SHCS		
										Mounting U or X	Mounting M or Y	UNC-2B U or X	ISO 6H M or Y		O-RING	Mounting U	Mounting M
0.75	0.75	1.94	2.81	.937	2.000	1.42	.83	1.250	.616	.406	10.5mm	0.375-16	M10-1.5	1.050	214	0.375-16x1.50	M10-1.5x40
1.00	1.00	2.18	3.19	1.093	2.250	1.61	.83	1.560	.817	.492	12.5mm	0.438-14	M12-1.75	1.315	219	0.438-14x1.50	M12-1.75x40
1.25	1.25	2.44	3.75	1.250	2.625	1.73	.94	1.750	1.162	.531	12.5mm	0.500-13	M12-1.75	1.660	222	0.500-13x2.00	M12-1.75x50
1.50	1.50	2.81	4.44	1.437	3.125	2.17	1.10	2.115	1.339	.656	16.5mm	0.625-11	M16-2.0	1.900	225	0.625-11x2.25	M16-2.0x55
2.00	2.00	3.44	5.25	1.750	3.812	2.48	1.46	2.490	1.691	.781	21.0mm	0.750-10	M20-2.5	2.375	228	0.750-10x3.00	M20-2.5x75
2.50*	2.50	5.00	6.88	2.312	4.875	2.37	1.50	2.995	2.127	.940	25.0mm	0.875-9	M24-3.0	2.875	232	0.875-9x3.00	M24-3.0x75
3.00*	3.00	6.00	8.50	2.812	6.000	2.96	2.00	3.615	2.626	1.190	31.0mm	1.125-7	M30-3.5	3.500	237	1.125-7x4.00	M30-3.5x100

\*2.50" and 3.00" flanges have 3000 PSI Max working pressure.

CODE 62 BUTT WELD - SCHEDULE XXS PIPE																	
FLANGE SIZE	PIPE SIZE	A	B	C	D	E	F	G	H	K DIA THRU		L THREAD		M	MOUNTING HARDWARE SHCS		
										Mounting U or X	Mounting M or Y	UNC-2B U or X	ISO 6H M or Y		O-RING	Mounting U	Mounting M
0.75	0.75	1.94	2.81	.937	2.000	1.42	.83	1.250	.436	.406	10.5mm	0.375-16	M10-1.5	1.050	214	0.375-16x1.50	M10-1.5x40
1.00	1.00	2.18	3.19	1.093	2.250	1.61	.83	1.560	.601	.492	12.5mm	0.438-14	M12-1.75	1.315	219	0.438-14x1.50	M12-1.75x40
1.25	1.25	2.44	3.75	1.250	2.625	1.73	.94	1.750	.898	.531	12.5mm	0.500-13	M12-1.75	1.660	222	0.500-13x2.00	M12-1.75x50
1.50	1.50	2.81	4.44	1.437	3.125	2.17	1.10	2.115	1.102	.656	16.5mm	0.625-11	M16-2.0	1.900	225	0.625-11x2.25	M16-2.0x55
2.00	2.00	3.44	5.25	1.750	3.812	2.48	1.46	2.490	1.505	.781	21.0mm	0.750-10	M20-2.5	2.375	228	0.750-10x3.00	M20-2.5x75
2.50*	2.50	5.00	6.88	2.312	4.875	2.37	1.50	2.995	1.773	.940	25.0mm	0.875-9	M24-3.0	2.875	232	0.875-9x3.00	M24-3.0x75
3.00*	3.00	6.00	8.50	2.812	6.000	2.96	2.00	3.615	2.302	1.190	31.0mm	1.125-7	M30-3.5	3.500	237	1.125-7x4.00	M30-3.5x100

\*2.50" and 3.00" flanges have 3000 PSI Max working pressure.

For standard pressure ratings, see page 3.