

Double O-ring Union

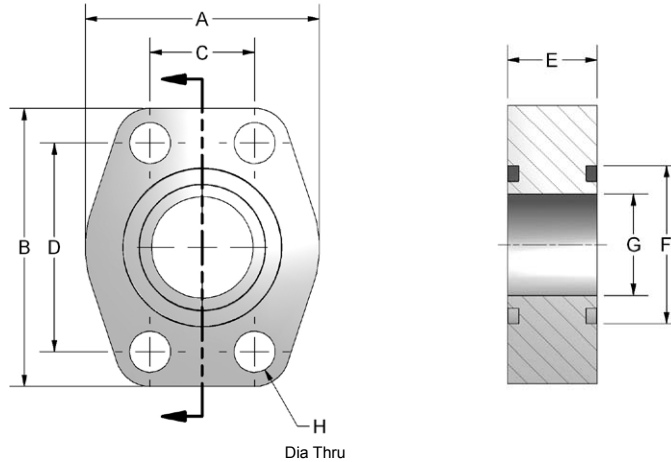
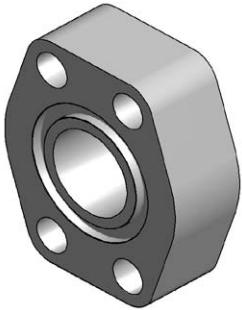

Ordering Information

FP	Flange Size	Material	Product Type	Rating Code	Mounting																																														
	<table border="1"> <thead> <tr> <th colspan="2">Flange Size</th> </tr> <tr> <td colspan="2">Rating code 1 or 2</td> </tr> </thead> <tbody> <tr> <td>08</td> <td>0.50"</td> </tr> <tr> <td>12</td> <td>0.75"</td> </tr> <tr> <td>16</td> <td>1.00"</td> </tr> <tr> <td>20</td> <td>1.25"</td> </tr> <tr> <td>24</td> <td>1.50"</td> </tr> <tr> <td>32</td> <td>2.00"</td> </tr> <tr> <td>40</td> <td>2.50"</td> </tr> <tr> <td>48</td> <td>3.00"</td> </tr> <tr> <td colspan="2">Rating code 1 only</td> </tr> <tr> <td>56</td> <td>3.50"</td> </tr> <tr> <td>64</td> <td>4.00"</td> </tr> </tbody> </table>	Flange Size		Rating code 1 or 2		08	0.50"	12	0.75"	16	1.00"	20	1.25"	24	1.50"	32	2.00"	40	2.50"	48	3.00"	Rating code 1 only		56	3.50"	64	4.00"	<table border="1"> <thead> <tr> <th colspan="2">Material</th> </tr> </thead> <tbody> <tr> <td>C</td> <td>Carbon Steel</td> </tr> </tbody> </table>	Material		C	Carbon Steel	<table border="1"> <thead> <tr> <th colspan="2">Product Type</th> </tr> </thead> <tbody> <tr> <td>U</td> <td>Double O-ring Union</td> </tr> </tbody> </table>	Product Type		U	Double O-ring Union	<table border="1"> <thead> <tr> <th colspan="2">Rating Code</th> </tr> </thead> <tbody> <tr> <td>1</td> <td>Code 61 • SAE J518 3.5 - 35 MPa • ISO 6162-1</td> </tr> <tr> <td>2</td> <td>Code 62 • SAE J518 40 MPa • ISO 6162-2</td> </tr> </tbody> </table>	Rating Code		1	Code 61 • SAE J518 3.5 - 35 MPa • ISO 6162-1	2	Code 62 • SAE J518 40 MPa • ISO 6162-2	<table border="1"> <thead> <tr> <th colspan="2">Mounting</th> </tr> </thead> <tbody> <tr> <td>X</td> <td>No kit included UNC mounting holes</td> </tr> <tr> <td>Y</td> <td>No kit included Metric mounting holes</td> </tr> </tbody> </table>	Mounting		X	No kit included UNC mounting holes	Y	No kit included Metric mounting holes
Flange Size																																																			
Rating code 1 or 2																																																			
08	0.50"																																																		
12	0.75"																																																		
16	1.00"																																																		
20	1.25"																																																		
24	1.50"																																																		
32	2.00"																																																		
40	2.50"																																																		
48	3.00"																																																		
Rating code 1 only																																																			
56	3.50"																																																		
64	4.00"																																																		
Material																																																			
C	Carbon Steel																																																		
Product Type																																																			
U	Double O-ring Union																																																		
Rating Code																																																			
1	Code 61 • SAE J518 3.5 - 35 MPa • ISO 6162-1																																																		
2	Code 62 • SAE J518 40 MPa • ISO 6162-2																																																		
Mounting																																																			
X	No kit included UNC mounting holes																																																		
Y	No kit included Metric mounting holes																																																		

Double O-ring Union

CODE 61 DOUBLE O-RING UNION										
FLANGE SIZE	A	B	C	D	E	F	G	O-RING	H DIA THRU	
									Mounting X	Mounting Y
0.50	1.813	2.125	.688	1.50	.750	1.000	.502	210	.344	8.5mm
0.75	2.063	2.563	.875	1.875	.750	1.250	.752	214	.406	10.5mm
1.00	2.313	2.750	1.031	2.063	.880	1.560	1.002	219	.406	10.5mm
1.25	2.875	3.125	1.188	2.313	.940	1.750	1.252	222	.469	10.5mm
1.50	3.250	3.688	1.406	2.750	1.190	2.115	1.502	225	.531	12.5mm
2.00	3.813	4.000	1.688	3.063	1.440	2.490	2.002	228	.531	12.5mm
2.50	4.281	4.500	2.000	3.500	1.815	2.995	2.502	232	.531	12.5mm
3.00	5.156	5.313	2.438	4.188	2.190	3.615	3.002	237	.656	16.5mm
3.50	5.500	6.000	2.750	4.750	1.440	4.095	3.502	241	.656	16.5mm
4.00	6.000	6.380	3.062	5.125	1.440	4.595	4.002	245	.656	16.5mm

O-rings not included. See page 5 for ordering information.

CODE 62 DOUBLE O-RING UNION										
FLANGE SIZE	A	B	C	D	E	F	G	O-RING	H DIA THRU	
									Mounting X	Mounting Y
0.50	1.94	2.30	.718	1.594	1.250	1.000	.502	210	.344	8.5mm
0.75	2.50	2.95	.937	2.000	1.250	1.250	.752	214	.406	10.5mm
1.00	2.75	3.19	1.093	2.250	1.500	1.560	1.002	219	.492	12.5mm
1.25	3.06	3.75	1.250	2.625	1.430	1.750	1.252	222	.531	12.5mm
1.50	3.75	4.44	1.437	3.125	1.815	2.115	1.502	225	.656	16.5mm
2.00	4.50	5.25	1.750	3.812	1.815	2.490	2.002	228	.781	21.0mm
2.50	5.87	6.87	2.312	4.875	1.930	2.995	2.502	232	.906	25.0mm
3.00	7.00	8.50	2.812	6.000	2.690	3.615	3.002	237	1.156	31.0mm

O-rings not included. See page 5 for ordering information.

Pressure Ratings and Fastener Torque Values

CODE 61 SAE J518-1 / ISO 6162-1					
Dash Size	Inch Size	Max Working Pressure		Fastener Torque Value	
		PSI	MPa	Grade 8 UNC (lb-ft)	Grade 10.9 Metric (N-m)
-8	0.50"	5000	35.0	24	32
-12	0.75"	5000	35.0	44	70
-16	1.00"	4600	32.0	44	70
-20	1.25"	4000	28.0	68	70
-24	1.50"	3000	21.0	111	130
-32	2.00"	3000	21.0	111	130
-40	2.50"	2500	17.5	111	130
-48	3.00"	2300	16.0	218	295
-56	3.50"	500	3.5	218	295
-64	4.00"	500	3.5	218	295
-80	5.00"	500	3.5	218	295

CODE 62 SAE J518-2 / ISO 6162-2					
Dash Size	Inch Size	Max Working Pressure		Fastener Torque Value	
		PSI	MPa	Grade 8 UNC (lb-ft)	Grade 10.9 Metric (N-m)
-8	0.50"	6000	40.0	24	32
-12	0.75"	6000	40.0	44	70
-16	1.00"	6000	40.0	68	130
-20	1.25"	6000	40.0	111	130
-24	1.50"	6000	40.0	218	295
-32	2.00"	6000	40.0	332	550

Please note that all pressure ratings in this catalog refer to the flange connection. Adapting the flange to other connections, such as braze tube, welded pipe, or threaded ports / stud ends could reduce maximum working pressure.