

# Male Thread ORFS

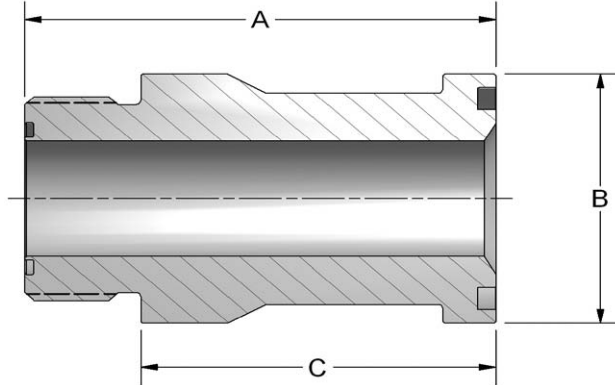
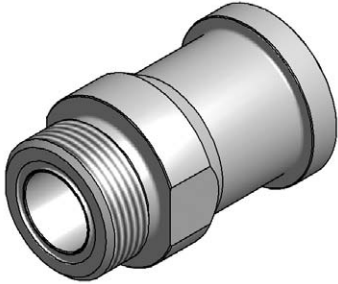

## Ordering Information

FF	Flange Size	Material	Product Type	Angle	Rating Code	Thread Size	Thread Type																																																		
	<table border="1"> <thead> <tr> <th colspan="2">Flange Size</th> </tr> </thead> <tbody> <tr> <td>08</td> <td>0.50"</td> </tr> <tr> <td>12</td> <td>0.75"</td> </tr> <tr> <td>16</td> <td>1.00"</td> </tr> <tr> <td>20</td> <td>1.25"</td> </tr> <tr> <td>24</td> <td>1.50"</td> </tr> <tr> <td>32</td> <td>2.00"</td> </tr> </tbody> </table>	Flange Size		08	0.50"	12	0.75"	16	1.00"	20	1.25"	24	1.50"	32	2.00"	<table border="1"> <thead> <tr> <th colspan="2">Material</th> </tr> </thead> <tbody> <tr> <td>C</td> <td>Carbon Steel</td> </tr> </tbody> </table>	Material		C	Carbon Steel	<table border="1"> <thead> <tr> <th colspan="2">Product Type</th> </tr> </thead> <tbody> <tr> <td>M</td> <td>Male Thread</td> </tr> </tbody> </table>	Product Type		M	Male Thread	<table border="1"> <thead> <tr> <th colspan="2">Angle</th> </tr> </thead> <tbody> <tr> <td>0</td> <td>Straight</td> </tr> </tbody> </table>	Angle		0	Straight	<table border="1"> <thead> <tr> <th colspan="2">Rating Code</th> </tr> </thead> <tbody> <tr> <td>1</td> <td>Code 61 • SAE J518 3.5 - 35 MPa • ISO 6162-1</td> </tr> <tr> <td>2</td> <td>Code 62 • SAE J518 40 MPa • ISO 6162-2</td> </tr> </tbody> </table>	Rating Code		1	Code 61 • SAE J518 3.5 - 35 MPa • ISO 6162-1	2	Code 62 • SAE J518 40 MPa • ISO 6162-2	<table border="1"> <thead> <tr> <th colspan="2">Thread Size</th> </tr> </thead> <tbody> <tr> <td colspan="2">Not all thread sizes are available for each flange size. See chart next page.</td> </tr> <tr> <td>08</td> <td>0.812-16</td> </tr> <tr> <td>12</td> <td>1.188-12</td> </tr> <tr> <td>16</td> <td>1.438-12</td> </tr> <tr> <td>20</td> <td>1.688-12</td> </tr> <tr> <td>24</td> <td>2.000-12</td> </tr> </tbody> </table>	Thread Size		Not all thread sizes are available for each flange size. See chart next page.		08	0.812-16	12	1.188-12	16	1.438-12	20	1.688-12	24	2.000-12	<table border="1"> <thead> <tr> <th colspan="2">Thread Type</th> </tr> </thead> <tbody> <tr> <td>R</td> <td>ORFS ISO 8434-3</td> </tr> </tbody> </table>	Thread Type		R	ORFS ISO 8434-3
Flange Size																																																									
08	0.50"																																																								
12	0.75"																																																								
16	1.00"																																																								
20	1.25"																																																								
24	1.50"																																																								
32	2.00"																																																								
Material																																																									
C	Carbon Steel																																																								
Product Type																																																									
M	Male Thread																																																								
Angle																																																									
0	Straight																																																								
Rating Code																																																									
1	Code 61 • SAE J518 3.5 - 35 MPa • ISO 6162-1																																																								
2	Code 62 • SAE J518 40 MPa • ISO 6162-2																																																								
Thread Size																																																									
Not all thread sizes are available for each flange size. See chart next page.																																																									
08	0.812-16																																																								
12	1.188-12																																																								
16	1.438-12																																																								
20	1.688-12																																																								
24	2.000-12																																																								
Thread Type																																																									
R	ORFS ISO 8434-3																																																								

# Male Thread ORFS

CODE 61 MALE THREAD ORFS					
FLANGE SIZE	TUBE O.D.	A	B	C	THREAD
0.50	0.50	2.45	1.188	1.94	0.812-16
0.75	0.75	2.75	1.500	2.08	1.188-12
0.75	1.00	2.75	1.500	2.06	1.438-12
1.00	0.75	2.80	1.750	2.13	1.188-12
1.00	1.00	2.80	1.750	2.11	1.438-12
1.00	1.25	2.80	1.750	2.11	1.688-12
1.25	1.00	2.80	2.000	2.11	1.438-12
1.25	1.25	2.80	2.000	2.11	1.688-12
1.25	1.50	3.20	2.000	2.51	2.000-12
1.50	1.25	3.50	2.375	2.81	1.688-12
1.50	1.50	3.50	2.375	2.81	2.000-12
2.00	1.50	3.33	2.812	2.64	2.000-12

O-ring not included.

CODE 62 MALE THREAD ORFS					
FLANGE SIZE	TUBE O.D.	A	B	C	THREAD
0.50	0.50	2.58	1.250	2.08	0.812-16
0.75	0.75	2.75	1.625	2.08	1.188-12
0.75	1.00	2.75	1.625	2.06	1.438-12
1.00	0.75	2.80	1.875	2.13	1.188-12
1.00	1.00	2.80	1.875	2.11	1.438-12
1.00	1.25	3.20	1.875	2.51	1.688-12
1.25	1.00	3.05	2.125	2.36	1.438-12
1.25	1.25	3.05	2.125	2.36	1.688-12
1.25	1.50	3.30	2.125	2.61	2.000-12
1.50	1.25	3.50	2.500	2.81	1.688-12
1.50	1.50	3.50	2.500	2.81	2.000-12
2.00	1.50	3.58	3.125	2.89	2.000-12

O-ring not included.

## Pressure Ratings and Fastener Torque Values

CODE 61 SAE J518-1 / ISO 6162-1					
Dash Size	Inch Size	Max Working Pressure		Fastener Torque Value	
		PSI	MPa	Grade 8 UNC (lb-ft)	Grade 10.9 Metric (N-m)
-8	0.50"	5000	35.0	24	32
-12	0.75"	5000	35.0	44	70
-16	1.00"	4600	32.0	44	70
-20	1.25"	4000	28.0	68	70
-24	1.50"	3000	21.0	111	130
-32	2.00"	3000	21.0	111	130
-40	2.50"	2500	17.5	111	130
-48	3.00"	2300	16.0	218	295
-56	3.50"	500	3.5	218	295
-64	4.00"	500	3.5	218	295
-80	5.00"	500	3.5	218	295

CODE 62 SAE J518-2 / ISO 6162-2					
Dash Size	Inch Size	Max Working Pressure		Fastener Torque Value	
		PSI	MPa	Grade 8 UNC (lb-ft)	Grade 10.9 Metric (N-m)
-8	0.50"	6000	40.0	24	32
-12	0.75"	6000	40.0	44	70
-16	1.00"	6000	40.0	68	130
-20	1.25"	6000	40.0	111	130
-24	1.50"	6000	40.0	218	295
-32	2.00"	6000	40.0	332	550

Please note that all pressure ratings in this catalog refer to the flange connection. Adapting the flange to other connections, such as braze tube, welded pipe, or threaded ports / stud ends could reduce maximum working pressure.