

Daman S02, S03, S71, S72, S83, S85 Servo Subplate; S02, S71 Pilot Port Tapping Plate

0.625, 0.780, 0.850, 0.938 Port Circle

Side Ported Subplate

Valve mtg **S02, S71**: UNF #10-32 x 0.63 DP or Metric M5-0.8mm ISO 6H x [16] DP
 Valve mtg **S03**: UNF 0.25-28 x 0.75 DP or Metric M6-1.0mm ISO 6H x [19] DP
 Valve mtg **S72, S83, S85**: UNC 0.25-20 x 0.75 DP or Metric M6-1.0mm ISO 6H x [19] DP
 Subplate hardware kit is supplied.
 See page 140 for itemized list.

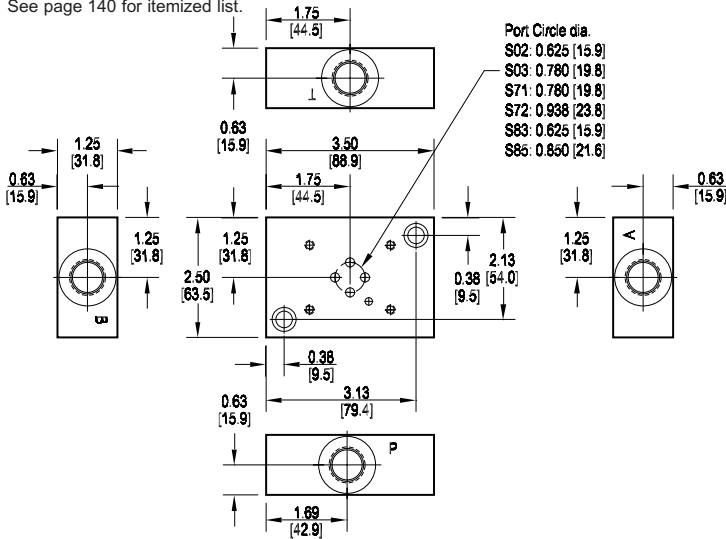

Pilot Port Tapping Plate (S02, S71 Patterns only)

Subplate interface seal kit is supplied.
 See page 140 for itemized list.

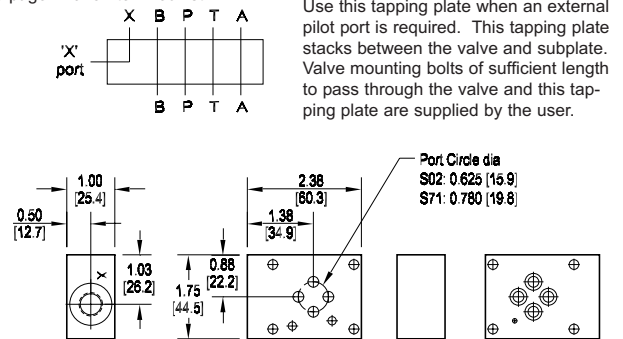

Specifications, descriptions, and dimensional data are subject to correction or change without notice or incurring obligation. Download latest catalog page revisions at www.damanifolds.com.

Ordering Information

Material	Servo Valve Pattern	Product Type	Port Location / Circuit	Port Threads
----------	---------------------	--------------	-------------------------	--------------

Material	
A	Aluminum - 6061-T6 3000† psi • 20.7 MPa
D	Ductile Iron - D4512 5000† psi • 34.5 MPa
† Working pressure should be considered in accordance with ISO 4413 to determine appropriate material type.	

Servo Pattern	
See page 125 and Tech Info	
S02	ISO 10372-02-02 Daman std. S02
S03	ISO 10372-03-03 Daman std. S03
S71	Daman std. S71
S72	Daman std. S72
S83	Daman std. S83
S85	Daman std. S85

Product Type	
SP	Subplate
TP	Tapping Plate S02 or S71 only

Port Loc. / Circuit	
S	Side ported (Subplate only)
X	X Port (Tapping Plate only)

Port Threads	
Subplate Port Sizes Only	
8S	-8 SAE ISO 11926; SAE 1926
8M	M18 x 1.5 ISO 6149
Tapping Plate Port Sizes Only	
4S	-4 SAE ISO 11926; SAE 1926
4M	M10 x 1.0 ISO 6149