

D07 Standard Flow Parallel Circuit Manifold

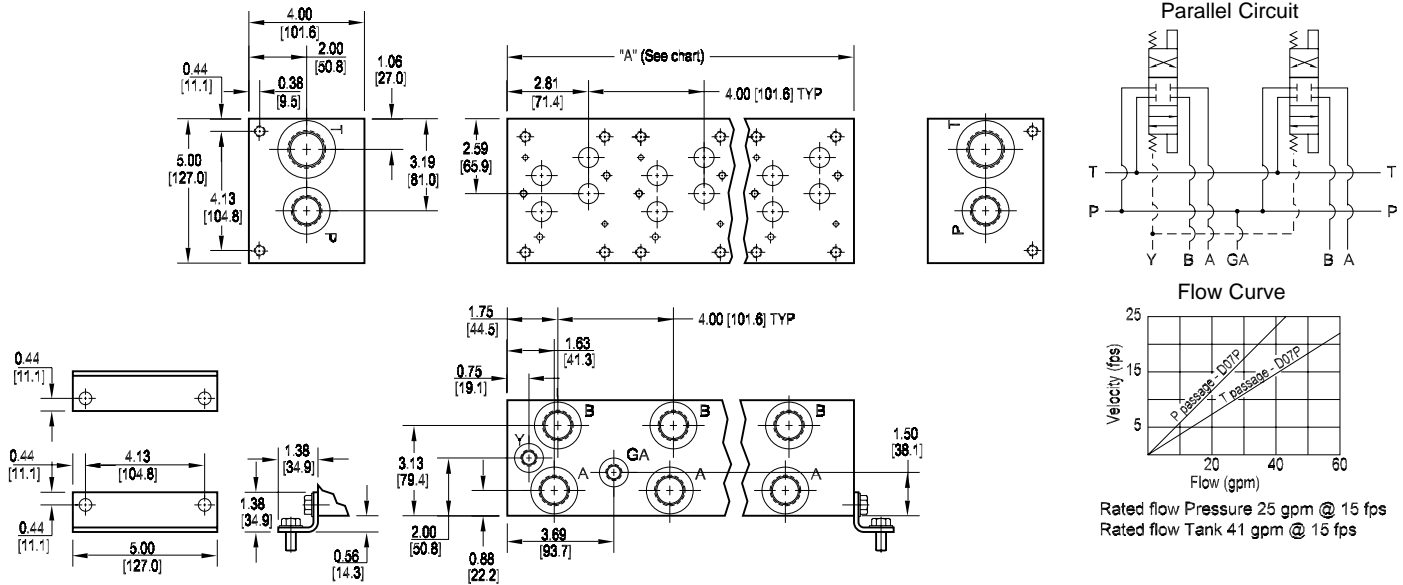

All mounting hardware is supplied.
See page 63 for itemized list.

No. of stations	* 01	02	03	04	05	06	07	08
"A" length (code 4 spa.) inch [mm]	4.00 [101.6]	8.00 [203.2]	12.00 [304.8]	16.00 [406.4]	20.00 [508.0]	24.00 [609.6]	28.00 [711.2]	32.00 [812.8]
apx. weight alum lb [kg]	6 [3]	14 [6]	22 [10]	30 [14]	38 [17]	46 [21]	52 [24]	60 [27]
apx. weight iron lb [kg]	24 [11]	46 [21]	69 [31]	90 [41]	114 [52]	135 [61]	158 [72]	180 [82]

Port code	Valve mtg.	Manifold mtg.
P, S	0.38-16 UNC x 1.00 [25] DP 0.25-20 UNC x 0.75 [19] DP	0.38-16 UNC x 0.75 [19] DP
B, M, T	M10 ISO 6H x 1.00 [25] DP M6 ISO 6H x 0.75 [19] DP	M10 ISO 6H x 0.75 [19] DP

Specifications, descriptions, and dimensional data are subject to correction or change without notice or incurring obligation.
Download latest catalog page revisions at www.damanifolds.com.

* Length of 01 sta. with "C" relief cavity 5.50 [139.7]. Gauge port not available on 01 station.

Ordering Information

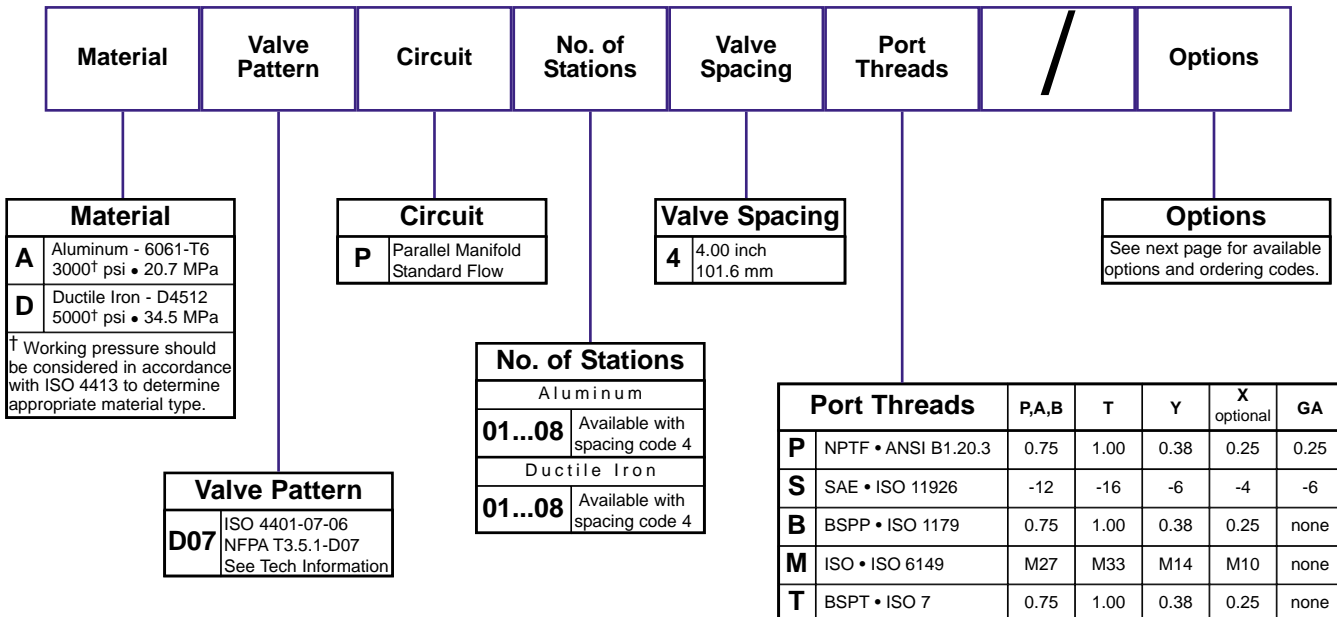

Options - D07 Standard Flow Parallel Manifold

Contact Daman or consult web CADalog for cavity locations if critical.

Valve cavity location when cavity, or cavity-isolation combination L or D is specified.

Valve cavity location for cavity-isolation combination R or D.

ISOLATIONS

Daman isolation options allow a manifold to have two independent pressure and/or tank ports. Isolations are drilled rather than plugged to ensure a leakproof and failproof isolation.

Ordering code letter:	* Isolation is between stations:	Available # of stations:
A	01 & 02	02-08
B	02 & 03	03-08
C	03 & 04	04-08
D	04 & 05	05-08
E	05 & 06	06-08
F	06 & 07	07-08
G	07 & 08	08

* Stations are numbered left to right.

Parallel Circuit with X

Parallel Circuit with Cavity

Valves with P in the nose and T out the side must be used.

Parallel Circuit with Isolations

Manifold shown with P isolation between 1 & 2 (PA), and T isolation between 2 & 3 (TB).

Cavity & Isolation Combinations

Option code L: Cavity left of isolation
Option code R: Cavity right of isolation
Option code D includes both cavities

NOTES:

- 1) The GA port is not available on a (1) station manifold.
- 2) The GA port is not available when a pressure isolation is located between stations 1 & 2.
- 3) Some cavity and isolation combinations are not possible. Consult factory to determine availability.

Ordering Information

...	Pilot Ports	Cavity	Pressure Isolation	Tank Isolation	Cavity & Isolation Combinations
	Pilot Ports Omit if X ports not required 1 X port ISO 4401-07-06 NFPA T3.5.1-D07	Cavity Omit if cavity not required C Common cavity: With solenoid clearance. C-10-2 (P in nose) S Sun Cavity: T-3A (P in nose) See Tech Info for valves.	Pressure Isolation Omit if P isolation not required PA...PG Available with spacing code 4	Tank Isolation Omit if T isolation not required TA...TG Available with spacing code 4	Cavity & Isolation Combinations Specify when using a combination of cavity and isolation options. Cavities do have solenoid clearance. L Relief cavity is located left of the isolation. R Relief cavity is located right of the isolation. D Two relief cavities, one each side of isolation.