

2F06, 2F07 Flow Control Cover Plates

Parallel Circuit Cover Plate 2F06 Pattern

Cover Plate mounting hardware is supplied.
See page 77 for itemized list.

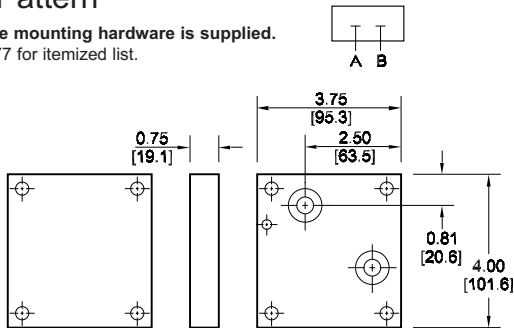

Parallel Circuit Cover Plate 2F07 Pattern

Cover Plate mounting hardware is supplied.
See page 77 for itemized list.

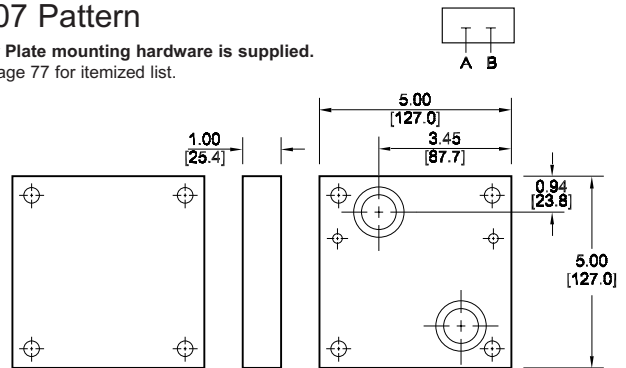

Specifications, descriptions, and dimensional data are subject to correction or change without notice or incurring obligation. Download latest catalog page revisions at www.damanifolds.com.

Ordering Information

